

機工實習課程 (6/16)

銑床加工

郭詩坪

e-mail: jeffcuo@webmail.pme.nthu.edu.tw

<http://edl.pme.nthu.edu.tw/newweb/tw/course.htm>

2008/04/18



郭詩坪 Jeff Cuo

Contents

- 銑床種類
- 銑刀
- 銑床加工



本內容參照資料：

1. 機工學, 張甘棠, 三文出版社
2. 工廠實習 蔡德藏, 全華出版社, ISBN 957-21-1548-0
3. 機械工作便覽, 張甘棠, 三文出版社
4. 網路資訊如各投影片網址所示



郭詩坪 Jeff Cuo

銑 床

銑床是機械加工中的重要工作母機之一，銑床能夠精確的將工作物銑平面、銑曲面、銑溝槽、銑齒輪、銑種種複雜的形狀，對機械生產、模具生產或工具生產作業來說，都是不可或缺的工作利器。



銑刀切削原理

- 利用多刃口的圓形刀具(銑刀)對工件作平面、輪廓或溝槽等切削加工，其加工運動形態為主軸與刀具一起旋轉，而工件對刀具作直線進給。用於平面切削、外圓周切銷、切槽等。



銑床的種類

□ 依其床台之構造可分柱膝式及床式兩種：

1. **柱膝式**：指心軸裝置在於機柱上者，床台高度可以隨工作需要而適當調整，屬於此類型的有臥式銑床、立式銑床、銑床等。

2. **床型銑床**：床台直接固定於基座於一定高度，工作時只能調節心軸獲得不同高度銑削，屬於此類型的有龍門銑床、生產式銑床等。



柱膝式銑床



立式銑床



臥式銑床



柱膝式銑床

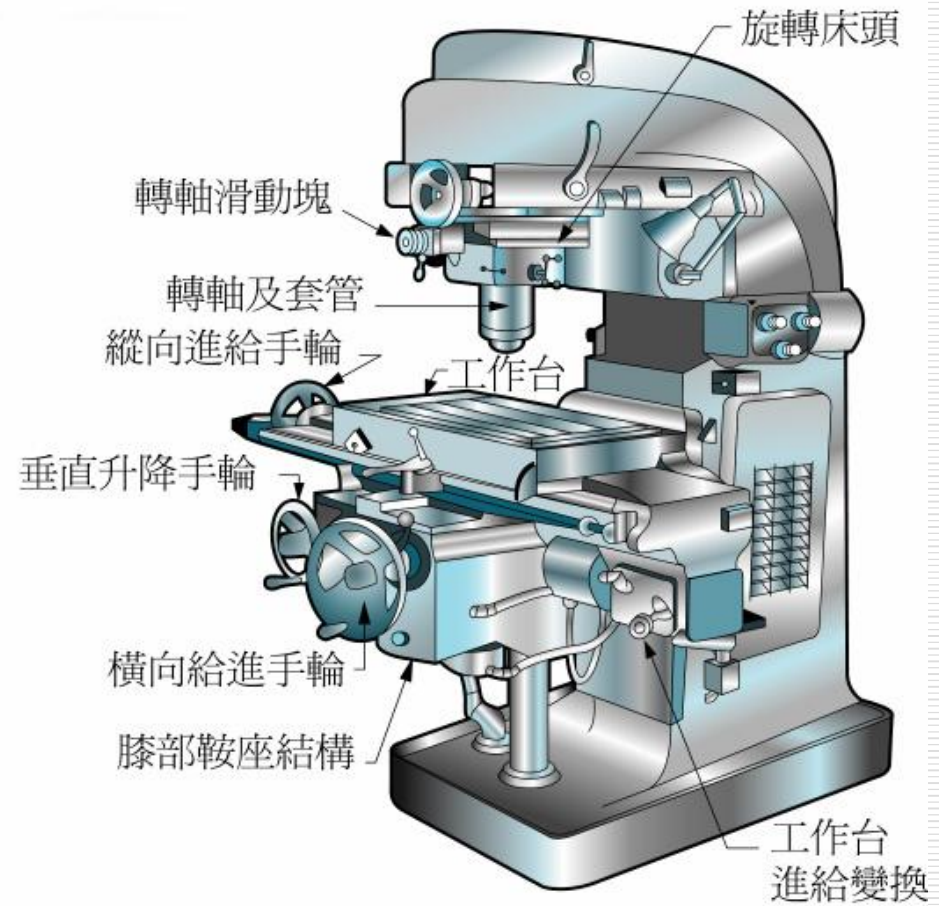

立臥式銑床

立式銑床操作功能圖

郭詩坪 Jeff Cuo



床型銑床

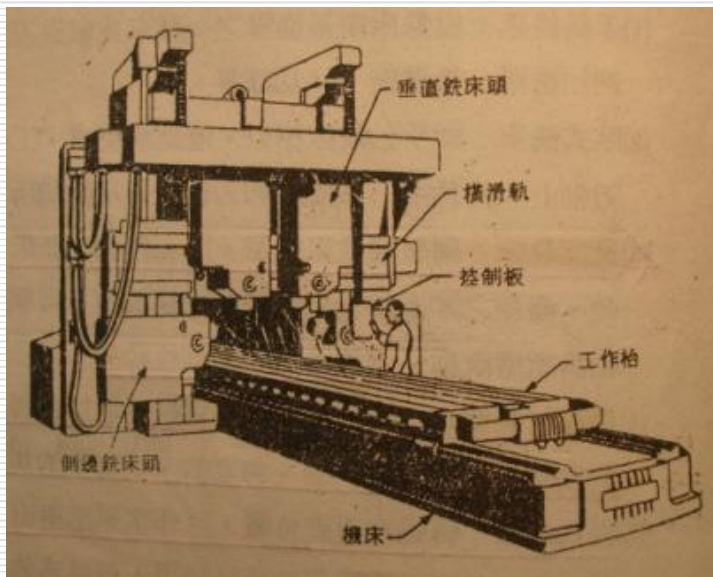
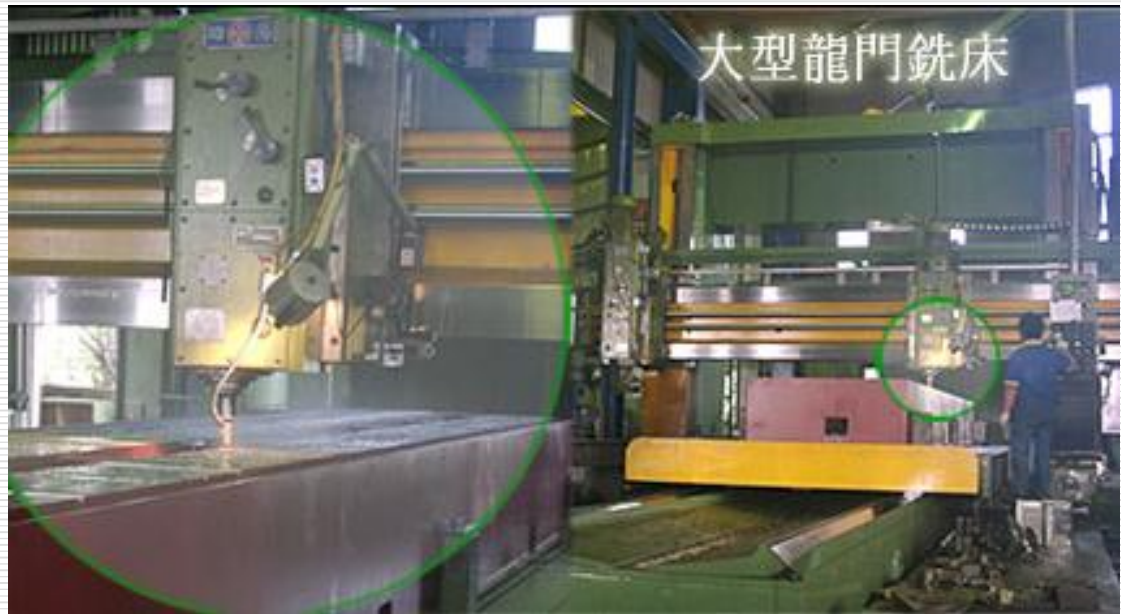

主要設備概況

名稱	規格
五面加工機	1000高 X 2700寬 X 5000長
CNC龍門切削機	1000高 X 2000寬 X 3200長 760高 X 1700寬 X 2000長
CNC搪床	1800高 X 1700寬 X 2000長
龍門銑床加工機	2500高 X 3700寬 X 8000長
	1600高 X 2400寬 X 6000長
	1200高 X 1600寬 X 5000長 1000高 X 1500寬 X 4000長



郭詩坪 Jeff Cuo

銑床規格

□ 床台移動距離或號數表示

稱呼 號數	機種別	床台移動距離 mm			稱呼 號數	機種別	床台移動距離 mm		
		左右 (縱向)	前後 (橫向)	上下			左右 (縱向)	前後 (橫向)	上下
NO.0	普通銑床	450	150	300	NO.3	普通銑床	850	300	450
	萬能銑床	450	150	300		萬能銑床	850	275	450
	立式銑床	450	150	300		立式銑床	850	300	350
NO.1	普通銑床	550	200	400	NO.4	普通銑床	1,050	325	450
	萬能銑床	550	175	400		萬能銑床	1,050	300	450
	立式銑床	550	200	300		立式銑床	1,050	350	400
NO.2	普通銑床	700	250	400	NO.5	普通銑床	1,250	350	500
	萬能銑床	700	225	400		萬能銑床	1,250	325	500
	立式銑床	700	250	300		立式銑床	1,250	400	450



銑刀



1. 鋸齒 Saw Tooth
2. 型齒 (Formed Tooth)
3. 插入齒 (Inserted Tooth)

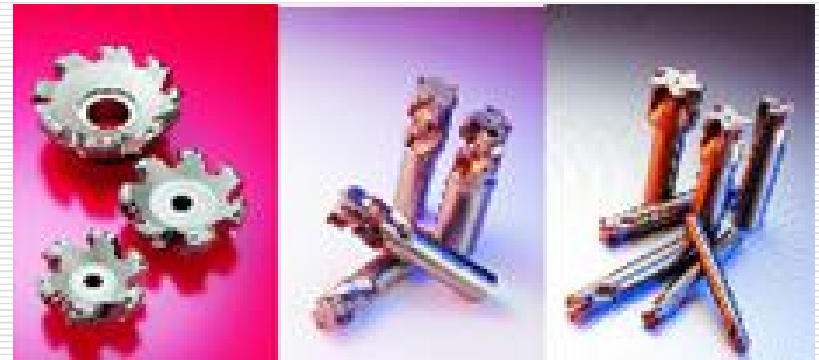

郭詩坪 Jeff Cuo

<http://www.echentools.com/main.php>

<http://www.full dare.com.tw/index.php?SID=306005>

立銑刀

[錫鋼微小徑2刃球型銑刀](#)



[錫鋼球型2刃球型銑刀](#)



[錫鋼球型4刃球型銑刀](#)



[錫鋼長頸球型2刃球型銑刀](#)



[錫鋼斜頸2刃球型銑刀](#)



[錫鋼斜度2刃球型銑刀](#)



[錫鋼鋁銅用2刃球型銑刀](#)



[錫鋼微小徑2刃立銑刀](#)



[錫鋼泛用型2刃立銑刀](#)



[錫鋼泛用型4刃立銑刀](#)



[錫鋼長頸2刃立銑刀](#)



[錫鋼長頸4刃立銑刀](#)



[錫鋼長柄2刃立銑刀](#)



[錫鋼長柄4刃立銑刀](#)



[錫鋼長柄長刃2刃立銑刀](#)



[錫鋼長柄長刃4刃立銑刀](#)



[錫鋼角R2刃立銑刀](#)



[錫鋼角R4刃立銑刀](#)



[錫鋼點數2刃立銑刀](#)



[錫鋼強力4刃立銑刀](#)



[錫鋼斜度2刃立銑刀](#)



[錫鋼倒角刀](#)

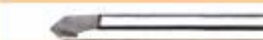

[錫鋼NC定點鑽](#)

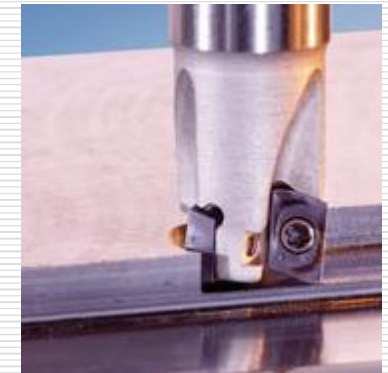

面銑刀

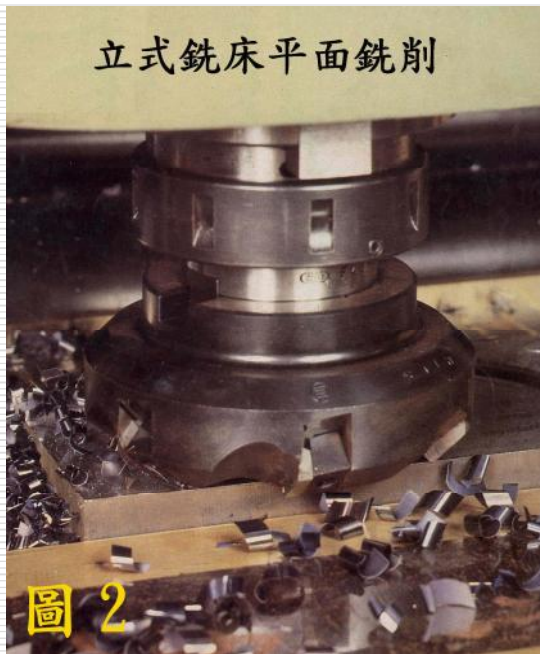

New



加長型溝面銑刀



端面銑刀



郭詩坪 Jeff Cuo

<http://www.full dare.com.tw/index.php?SID=30513>

面銑刀刀片

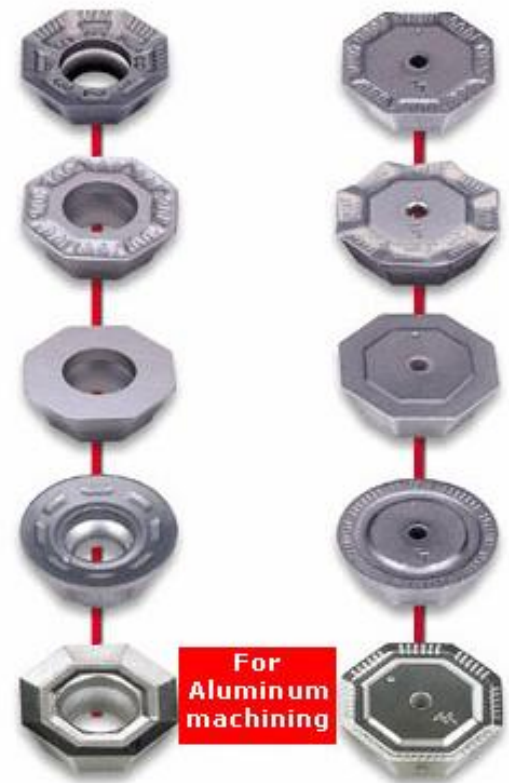

特殊訂製銑刀及工具



標準長度立銑刀
& 長型立銑刀



可通冷卻劑
立銑刀



側銑刀



圖 11.23 銑刀各部名稱



銑床加工範例

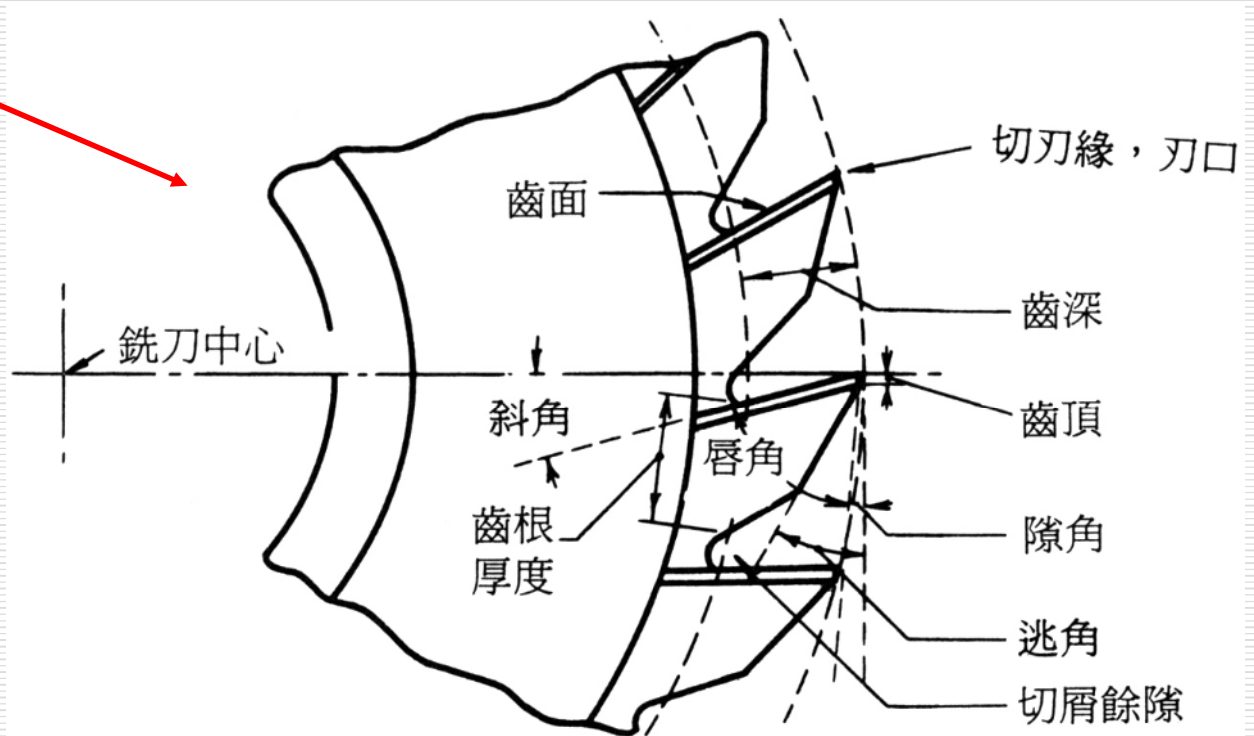
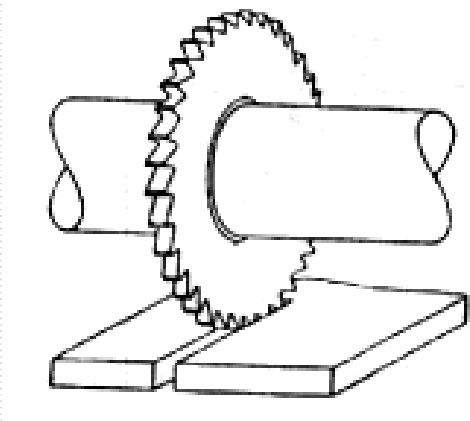
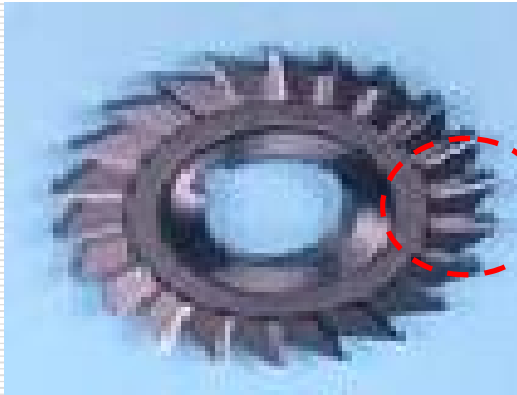

圖 7-3 平面銑削



圖 7-2 周邊銑削

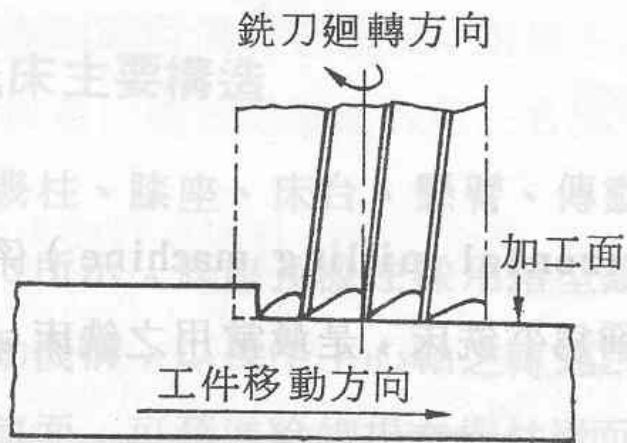

銑床加工範例-影片

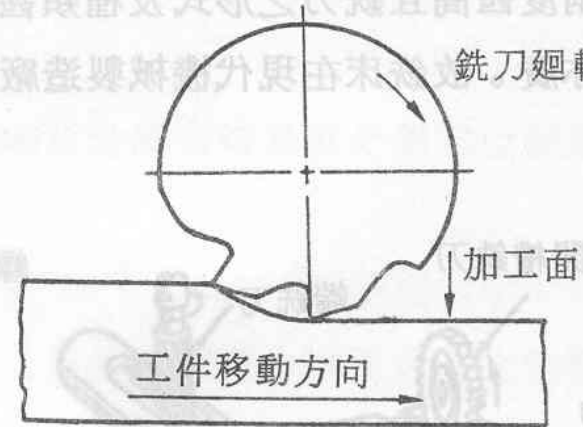
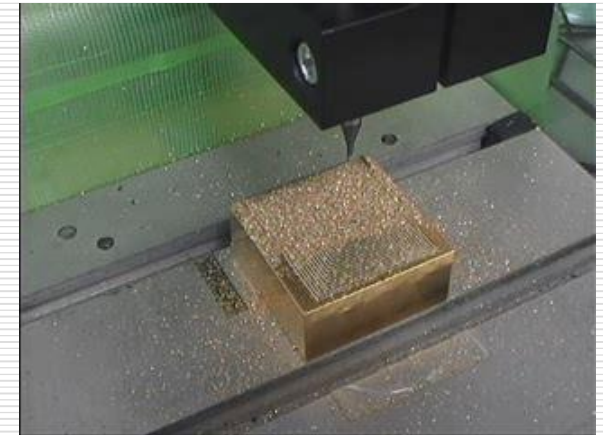

分度頭

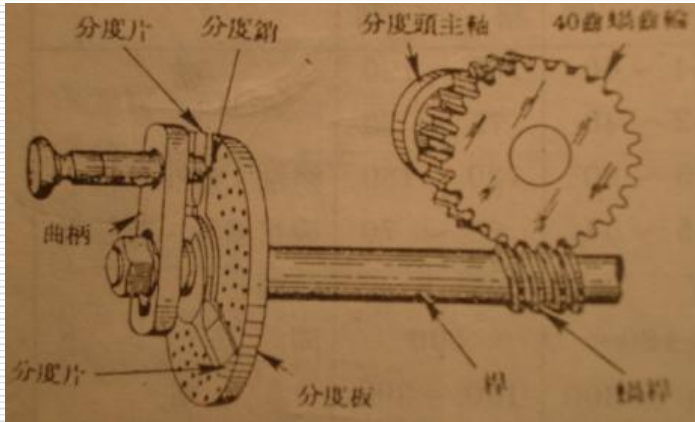

搖柄轉數 = 40/N (欲等分數)

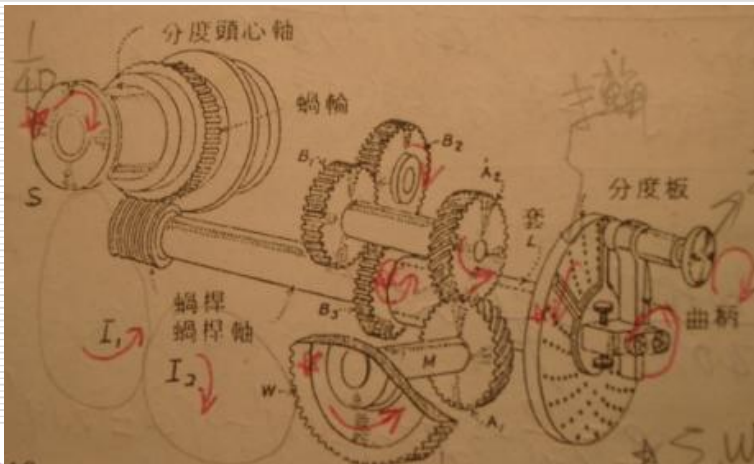

S與W齒配比

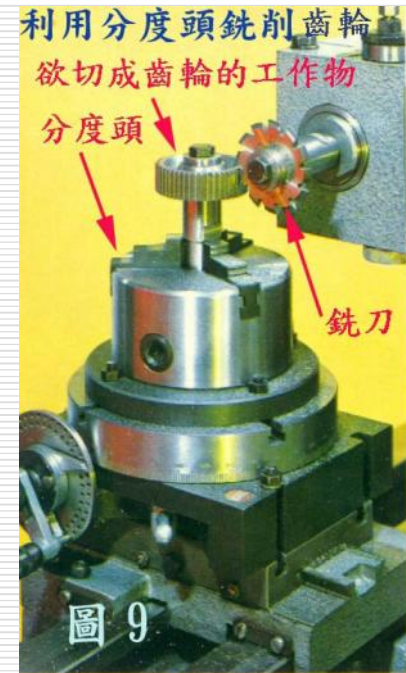

分度頭

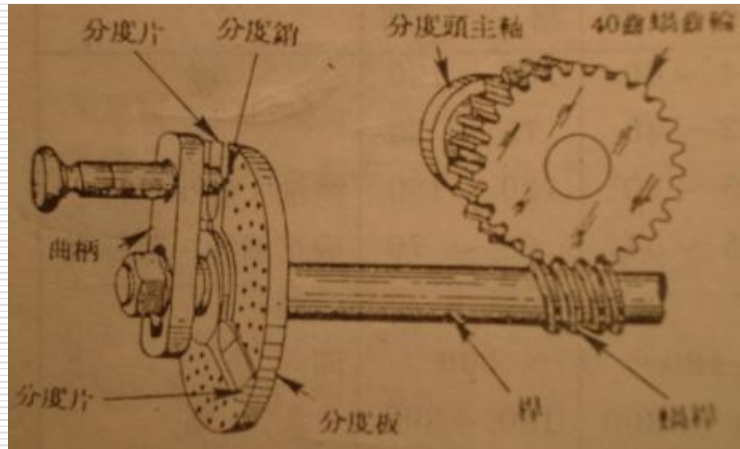

搖柄轉數 = 40/N (欲等分數)

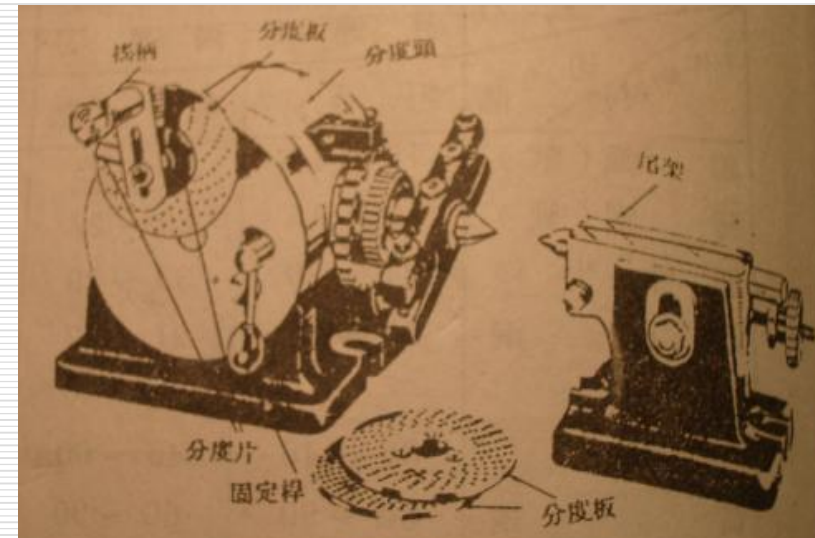
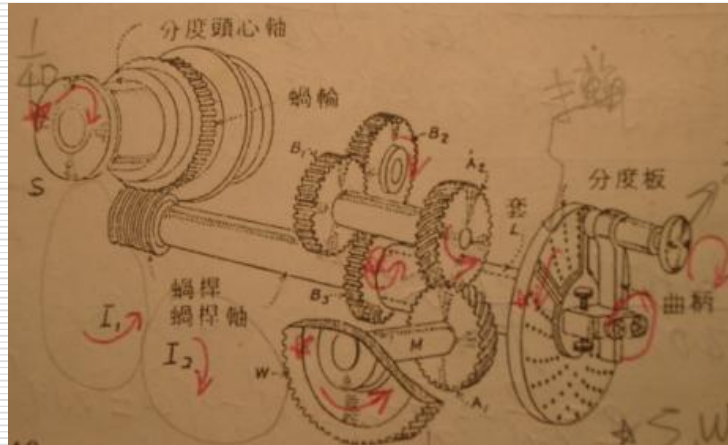

S與W齒配比

